

# CARDINGMILL BAY MOORING OWNERS ASSOCIATION

## STANDARD MOORING DESIGN

V.3  
2008

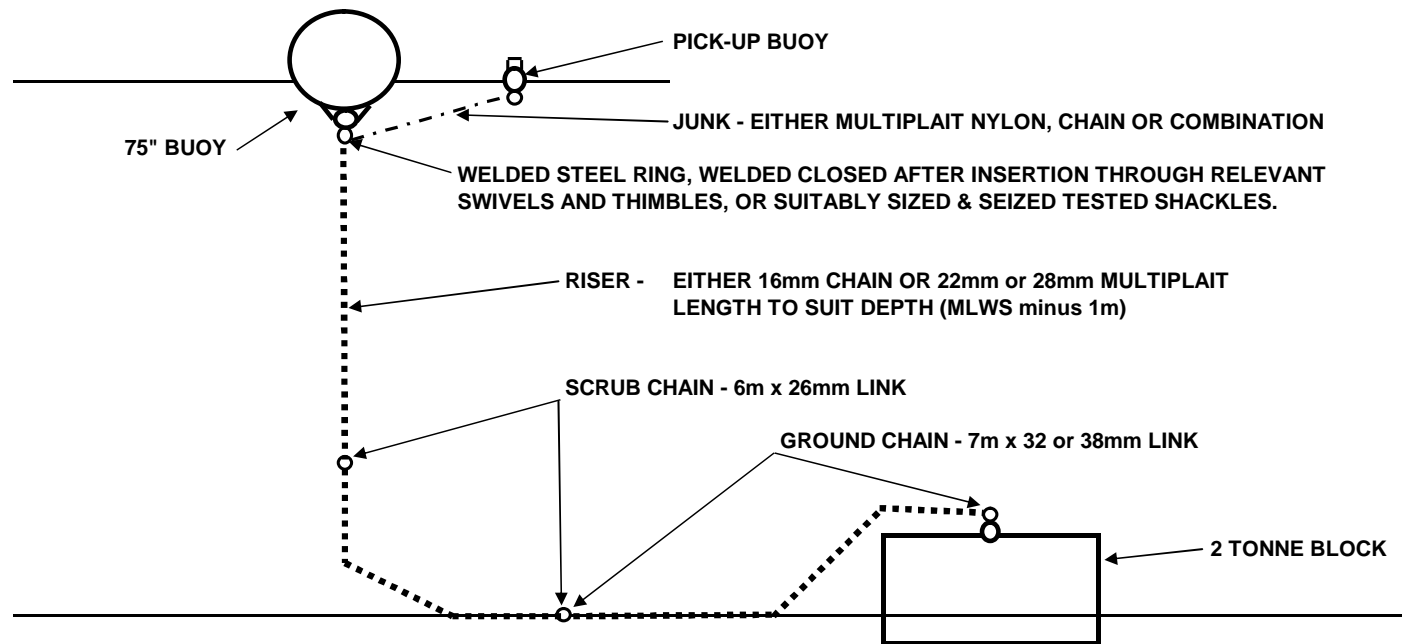

**NOTES:-** THIS DESIGN SHOULD BE SUITABLE FOR BOATS UP 35ft LENGTH OVERALL.  
ABOVE 35ft LOA, A LARGER BLOCK MAY BE REQUIRED.

ONLY TESTED SWIVELS AND SHACKLES SHALL BE USED.

ALL MATERIALS SHALL BE OF A SUITABLE QUALITY AND MATERIAL FOR USE  
IN A MARINE ENVIRONMENT.

ALL MOORINGS MUST BE CHECKED AND MAINTAINED ANNUALLY, AND CERTIFIED FIT FOR PURPOSE  
BY A PROFESSIONAL MOORINGS CONTRACTOR HOLDING LIABILITY INSURANCE COVER.